

**INSTALLATION INSTRUCTIONS**  
**Lectric I \$ III Screen**

**PLEASE READ THESE IMPORTANT SAFETY INSTRUCTIONS**

- Read and understand all instructions before installing and using.
- Close supervision is necessary when Projection Screen is used by or near children. Do not leave Screen unattended while in used.
- Installer must ensure that the mounting structures and fasteners must be of adequate strength to securely support the screen so that vibrations or even abusive pulling on the screen surface will not cause the housing to work loose or fall.
- The Screen is provided with toggle Switch that needs to be installed and wired by a qualified service man following the wiring diagram shown in Operation section of this manual. Wiring must conform to local and/or national electric codes and regulations.
- Do not operate Screen with a damage cord or if the Screen has been dropped or damage – until it has been examined by a qualified serviceman.
- DO NOT place or attach anything to metal casing or viewing screen.
- Position cord so that it will not be tripped over, pulled, or contact hot surfaces.
- DO NOT plug the cord in with wet hands; electric shock could occur
- DO NOT under any circumstances cut or remove the third (Ground) prong from power cord. For personal safety, this Projection Screen must be properly grounded.
- To reduce the risk of electric shock, do not disassemble this Projection Screen, but take it to a qualified serviceman when service or repair is required. Incorrect reassembly can cause electric shock when Screen is used subsequently,
- If an extension cord is necessary, it is absolutely necessary that it is UL-Listed, 3-wire grounding type appliance extension cord having a grounding type plug and outlet. The electrical rating of the extension cord must be equal or greater that the rating of the projection screen.
- The use of an accessory attachment not recommended by the manufacturer may cause a risk of fire, electric shock, or injury to persons.

**“SAVE THESE INSTRUCTIONS”**



**VUTEC CORPORATION**

## **LECTRIC I & III** **WALL OR UNDER CEILING MOUNT**

### **GENERAL**

The *LECTRIC I or III* screen may be mounted to the wall or ceiling as shown in Figures 1 and 2. Letric I and Letric III meet requirement for fire-resistant and low smoke-producing characteristics. The screen comes with three mounting brackets and screws as shown in Figures 3 and 4. Where possible, the mounting brackets should be installed to rigid structural members. If this is not possible, suitable wall anchors or other mounting methods must be considered.

Unless otherwise specified, the motor locates on the left end of the housing. The screen fabric rolls down from the backside of the roller.

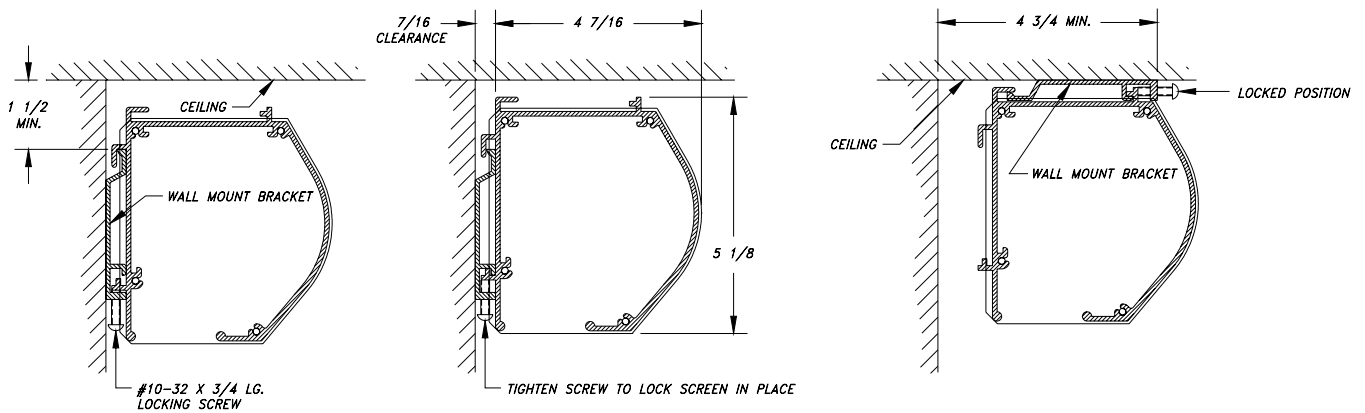

A basic Toggle switch is supplied with the screen. Decorator wall switch or other controls are optional.

**Figure 1**  
Wall Mounted

**Figure 2**  
Ceiling Mounted

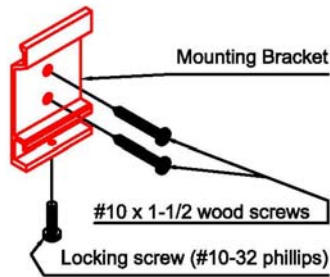

**Figure 3**  
Wall Mounted

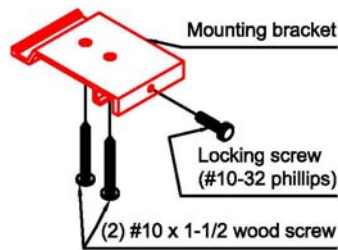

**Figure 4**  
Ceiling Mounted



**VUTEC CORPORATION**  
2741 N.E. 4<sup>th</sup> Avenue  
Pompano Beach, FL 33064  
TEL: (954) 545 9000 - FAX: (954) 545 9011  
E-MAIL: info@vutec.com

**Important considerations when deciding the mounting location for the screen.**

- The Housing Length (Figure 5) is as follow:  
 $Housing\ Length = Viewing\ Width + 10\ 1/4$  (Lectric I)  
 $Housing\ Length = Viewing\ Width + 17\ 1/2$  (Lectric III)
- The screen is centered in the housing.
- The housing may be moved left or right after it has been hang for final location.

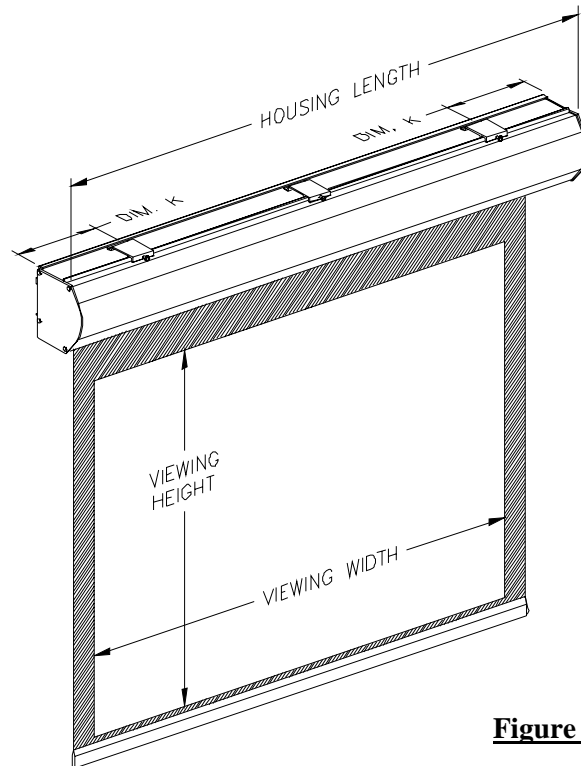

**Figure 3**

**INSTALLATION**

Determine the housing length and Dim. K. A third mounting bracket is recommended for middle support for screen of 96 inches viewing width or larger.

Dim. K should be approximately 1/6 to 1/8 of Housing Length.

Install the mounting brackets as required. Be sure they are level and in-line for proper contact with the housing.

*Note: If the screen is wall mount, the mounting brackets must be at least 1 1/2 inches from the ceiling as shown in Figure 1. If the screen is ceiling mount, the mounting brackets must be at least 4 3/4 inches from the wall (Figure2).*

Back-off the locking screw for each mounting bracket so that it is even with the inside face of the bracket.

Slightly tip the screen housing and fit it into the mounting brackets. If this is a ceiling installation, move the screen housing toward the rear immediately after the insertion so the screen is completely hooked to the brackets (see Figure 2).

Carefully move the screen housing side to side for desired location.

Tighten the locking screw of each bracket to lock the screen in place.



**VUTEC CORPORATION**  
 2741 N.E. 4<sup>th</sup> Avenue  
 Pompano Beach, FL 33064  
 TEL: (954) 545 9000 - FAX: (954) 545 9011  
 E-MAIL: info@vutec.com

## **OPERATION**

***Notice: The initial hook-up and calibration procedures are intended to be performed by a qualified service man.***  
Install the switch in a desired location and connect the wires per either wiring diagrams shown.

Wirings must conform to local and/or national electrical codes and regulations.

Dashed wirings shown by installers. Wirings must be of minimum 18-AWG. Install ring terminal provided to ground wire and attached to screw with ground symbol  $\oplus$  located on motor bracket.

Press “**DOWN**” on the switch and the screen will travel down to its lower limit and stop automatically.

Press “**UP**” on the switch and the screen will travel up to its upper limit and stop automatically.

The control switch should be left in the center “**OFF**” position when operation has completed.

See **Limit Switch Operation** for adjustments of the upper and lower limits. This information can be found on Vutec Website at [www.vutec.com](http://www.vutec.com).

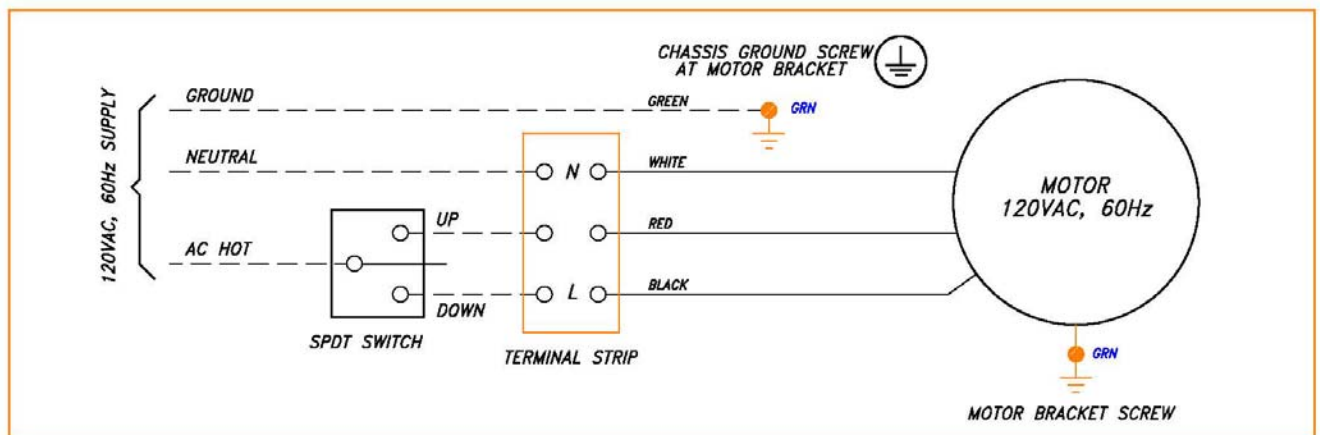

## **WIRING DIAGRAM - 120VAC**

### **ACCESSORIES INCLUDED**

- 1 **SPDT TOGGLE SWITCH**
- 1 **COVER PLATE FOR SWITCH**
- 3 **MOUNTING BRACKETS WITH SCREWS**



**VUTEC CORPORATION**  
2741 N.E. 4<sup>th</sup> Avenue  
Pompano Beach, FL 33064  
TEL: (954) 545 9000 - FAX: (954) 545 9011  
E-MAIL: [info@vutec.com](mailto:info@vutec.com)